

## STANDARD

### Motorised trolley

Up to 95" monitor.  
Electrical motor for height adjustment (650mm excursion)  
High end mounting solution: elegant and powerful system  
for wide range of displays.

## HMIFSTNDRD-F

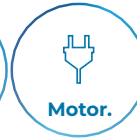

## Specifications

Accommodates displays from 32 to 95 inches

Ideal solution for touch displays in education, corporate, digital signage or event fields

Portable and easy to move between rooms

Max. height movement: 650 mm

Optional HMICOVER front decorative wood style panel, available in different colors.

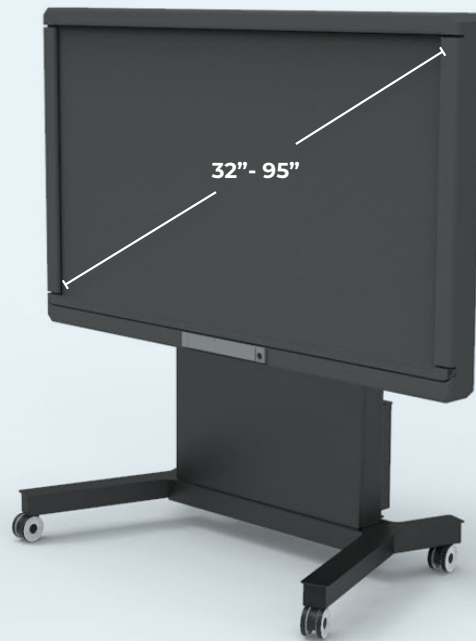

Display lock

Simple installation & operation

Wheel system with brakes

CE certified

Accessories:

Nylon drag chain for cable management

HMICAGE back box for allocating small devices used in the installation such as MINI PC, wifi access point, etc.

Motor control through smartphone app or tablet

Automatic safety stop function when motor finds an obstacle

## Product Details



### Built in power socket

Allowing an easy & comfortable powerment



### Anti-Collision function (Optional)

Integrated sensor minimising the risk of collision with obstacles in the up & down direction.



### Wireless control (Optional)

Motor control via bluetooth with app.



### Cable management (Optional)

Energy chain to ensure the supply of energy while in constant motion.



### Easy access

102 cm clearance between the wheels



### Flexible solution

Easy to move from one room to another

Code HMIFSTNDRD-F		
WEIGHT & DIMENSIONS	Weight	50 kg
	Width	740 mm
	Depth	120 mm
	Height	1650 mm
	Type of packaging	Carton
TECHNICAL DETAILS	Number of wheels	4
	Type of base	H-shaped
	Motorized	Yes
	Lockable wheels	Yes
ERGONOMICS	Height adjustment	Yes
	Rotating	No
	Tiltable	No
	Cable management	Optional
	Height adjustment range	0 - 650 mm
	Adjustable width	No
	Adjustable shelves	Optional
	Post-installation leveling roll	Yes
	Remotely controlled	Wired control: yes App via Bluetooth: optional
	Telescopic	Yes
	USB Hub integrated	No
	Anti-collision	Optional
	Height adjustment type	Electric
	On/Off Switch	Yes

MOUNTING	Minimum screen size	32"
	Maximum weight (capacity)	160 kg
	Maximum screen size	95"
	Mounting type	Floor
	Minimum VESA mount	200 x 200 mm
	Maximum Vesa mount	900 x 600 mm
	Panel mounting interface	200 x 200,300 x 400,300 x 300,300 x 200,400 x 200,400 x 400,400 x 300,400 x 600,600 x 200,600 x 300,600 x 400,600 x 600,600 x 500,800 x 200,800 x 400,800 x 500,800 x 600,900 x 600
MOUNTING	Minimum distance to floor	778 mm
	Maximum distance to floor	1650 mm
DESIGN	Product colour	Black
	Orientation	Horizontal/Landscape
	Certification	CE
	Housing material	Steel
PACKAGING CONTENT	User manual	Yes
	Portable remote control	Yes
	Mounting kit	Yes
	Packaging content	Structure + floor base + display plate + installation guide + screws-bolts-nuts + castors
<b>OTHER FEATURES</b>		
Wheels included		
<b>WARRANTY</b>		5 years

## VESA Display Mounts

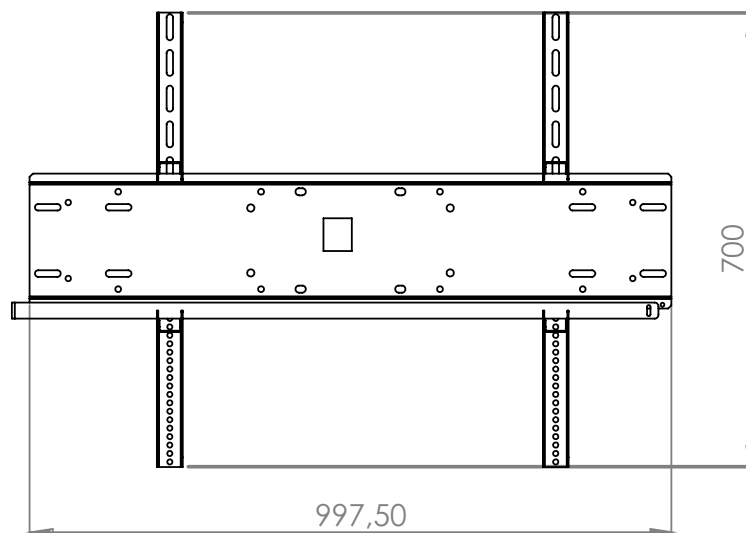

## Display Heights

Two different display installation plate fixing points

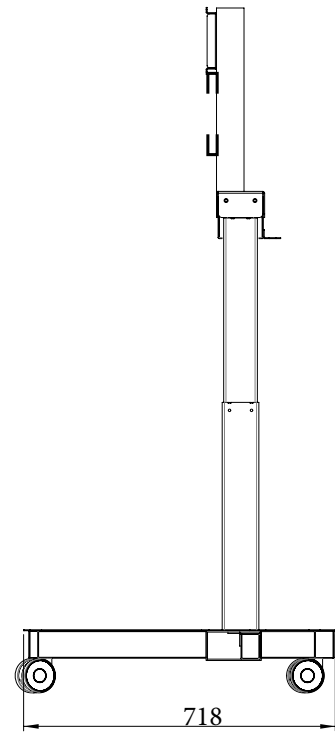
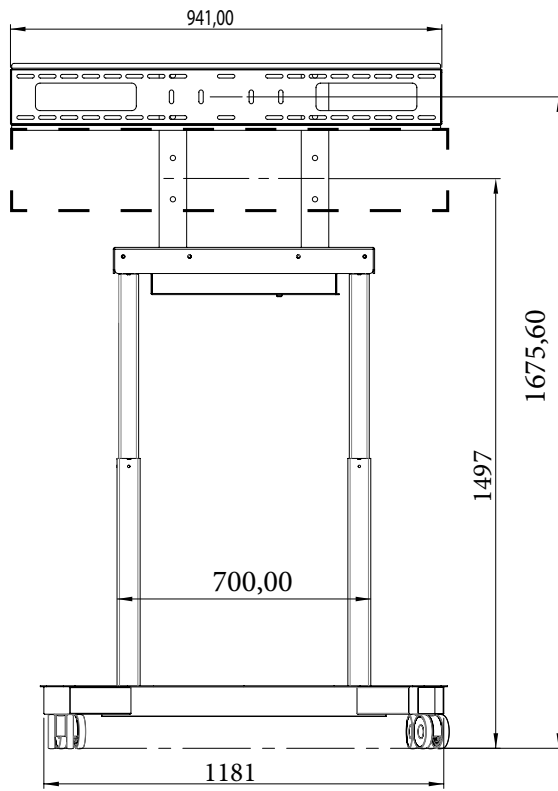

Top position

Two different display installation plate fixing points

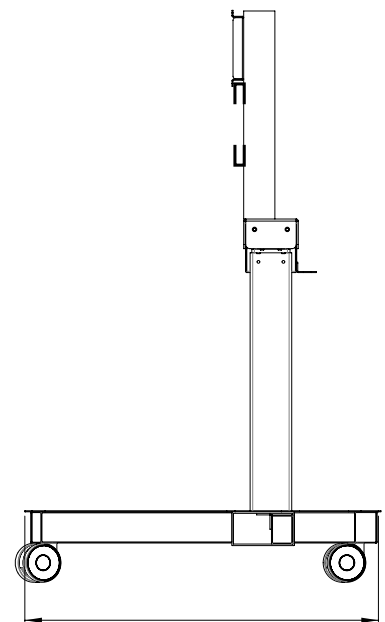
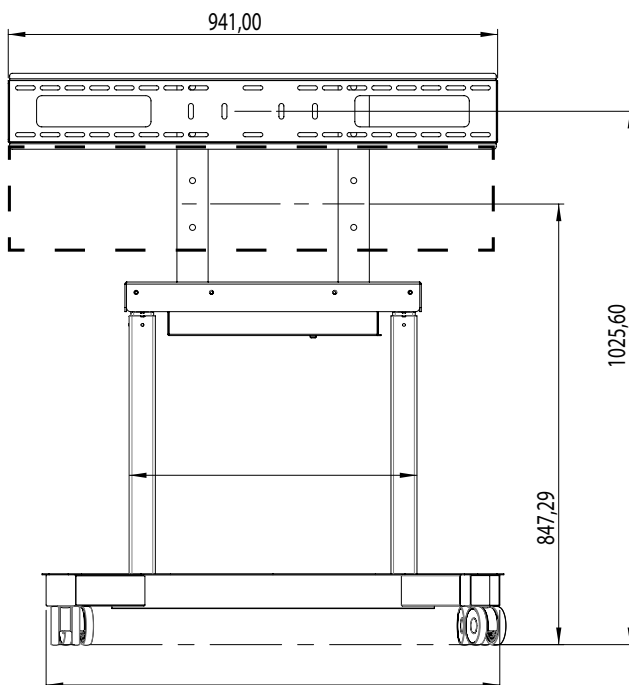

Bottom position

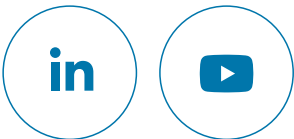

[www.HELGI-europe.com](http://www.HELGI-europe.com)

**HELGI Europe**  
education@helgi-europe.com  
business@helgi-europe.com

#T90521HMIFSTNDRD-F\_EN

Distributor